

REVISION RECORD				
REV	ECN	DESCRIPTION	DRFT	DATE

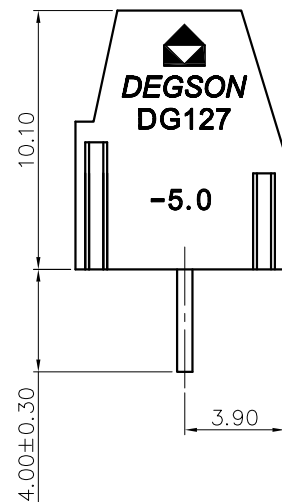
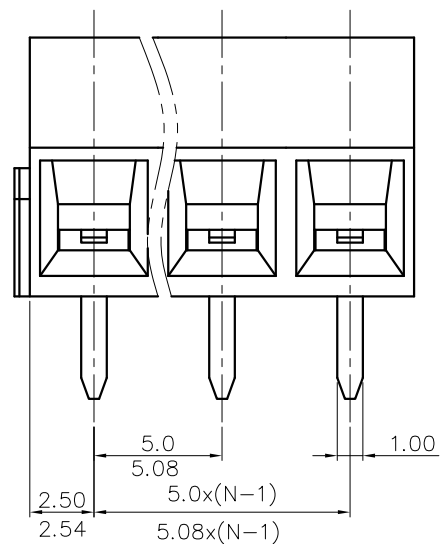
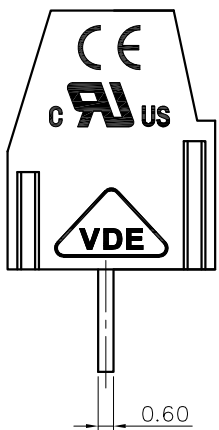
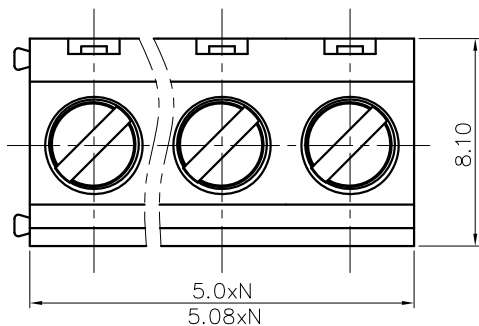

NOTES1:

UL Standard

1. Rated Voltage/Current : 300V / 12A
2. Torque Value : M2.5 , 3.54Lb.in
3. Wire Range : 26~14AWG

IEC Standard

1. Rated Voltage/Current : 250V / 15A
2. Torque Value : M2.5 , 0.4N.m
3. Wire Range : 1.5mm²

NOTES2:

1. Dimension shall be interpreted per ASME Y14.5-2009
2. Pitch : 5.0/5.08mm, Poles : N=02~24P
3. Stripping length : 5mm
4. Withstanding Voltage : AC2000V/1Min.
5. Operating temperature : -40°C~+105°C
6. Undimensioned Tolerances:

Pitch range in mm		Nominal dimension range in mm					0.1/10
To	Over	To	Over	To	Over		
6	10	6	10	30	60	100	150
±0.15	±0.20	±0.30	±0.30	±0.50	±0.70	±1.00	±1.30
							±2'

7. RoHS Compliance

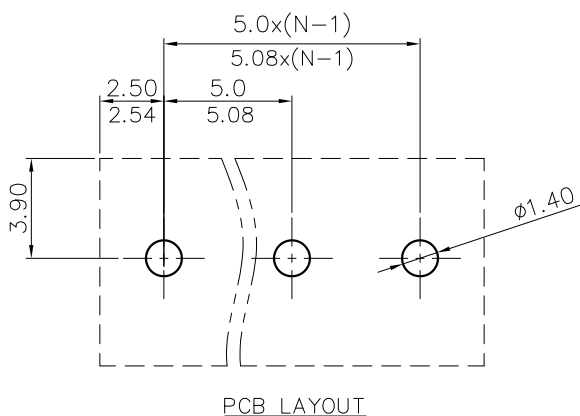
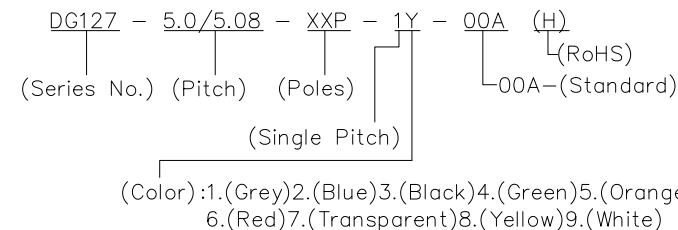

DETACHED LISTS	PART NO.:	/			
	APPD:	/			
	CHKD:	/			
	DRFT:	/			
		宁波高松电子有限公司 NINGBO DEGSON ELECTRICAL CO., LTD		NAME: DG127-5.0/5.08-XXP-1Y-00A(H)	
		TITLE: CUSTOMER DRAWING		REV	DO
		DRAWING NO.:		SHEET	1/1
		THIRD ANGLE PROJECTION		DO NOT SCALE DRAWING	SCALE: 1:1