

CABLE MARKING: ◀VDE▶KEMA-KEUR CEBEC IEMMEQU Ⓟ Ⓝ Ⓢ Ⓜ ÖVE +s+s+s NF-USE-1336 ◀SABS▶ ▲  
 SAI EA TE4274 4V-75 V-75 250 /440V ORDINARY DUTY H05VV-F 3G 0.75

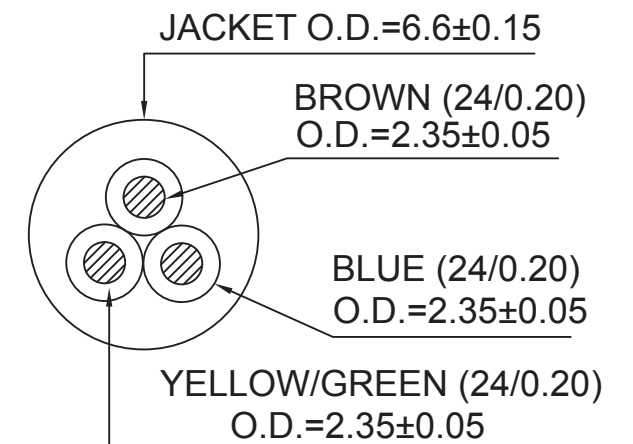
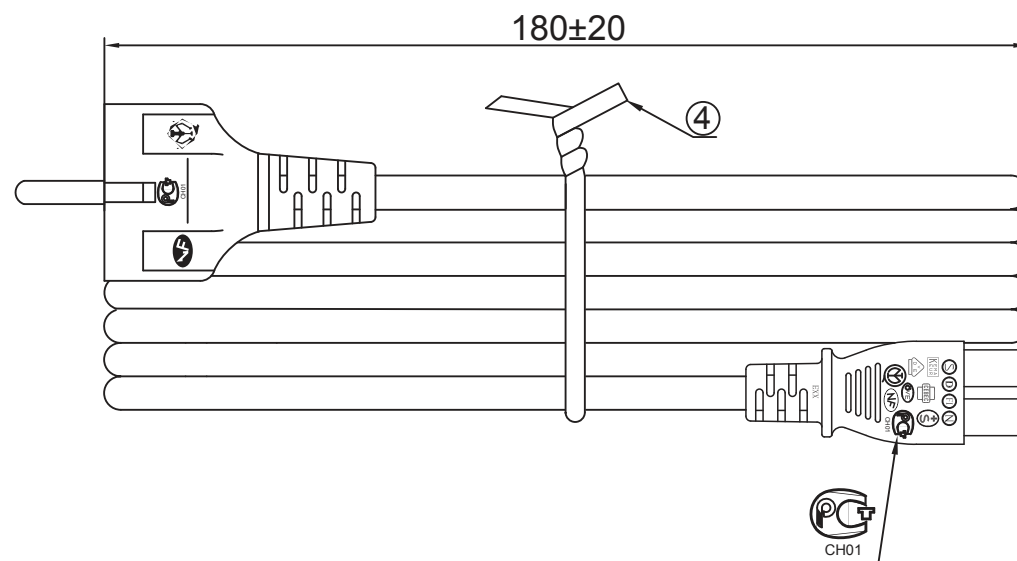
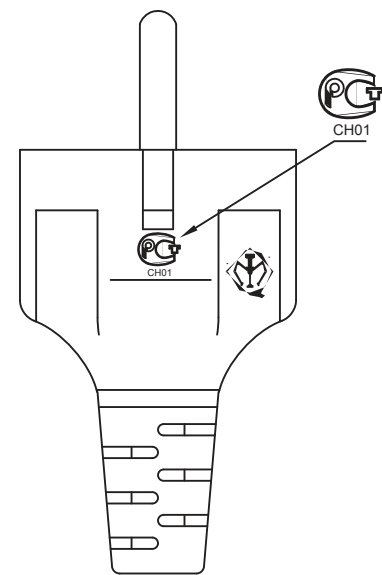

CROSS-SECTION VIEW

- NOTES:  
 1.CABLE: THE CORD SHALL COMPLY WITH IEC60227.  
 2.PLUG: THE MOLDED PLUG SHALL COMPLY WITH IEC60884-1.  
 3.CONNECTOR: THE MOLDED CONNECTOR SHALL COMPLY WITH IEC60320-1 STANDARD(C13 CONNECTOR).  
 4.THE PRODUCT SHALL BE TESTED 100% FOR ALL SAFETY ELECTRICAL ITEMS.  
 5.COLOR: BLACK(EA0000)  
 6.PRINT: INDENT PRINT  
 7.THE PRODUCT SHOULD COMPLY WITH RoHS STANDARD.

1		Original Picture		
REV	ECN NO	DESCRIPTION	APPD.	DATE

4	PE MINI TIE: BLACK	1	EA
3	MOLDED CONNECTOR:LS-15 2.5A/250V	1	EA
2	MOLDED PLUG:LP-34 16A/250V	1	EA
1	H05VV-F 0.75mm 3C BLACK 6'	1	EA

ITEM	DESCRIPTION	Q'TY	U/M
Tolerance:	Approved by:	<b>2Direct GmbH</b> P/N: CP093 DWG. NO: GL0806766 SHEET 1 OF 1	
>0±0.3	Checked by:		
>1±0.5	Drawn by:		
>10±1	Date:		
>20±2	Scale: X Unit: mm		
Angle:		REV: 1	
±1°		<b>Specification Use Only</b>	