

GMC TYPE

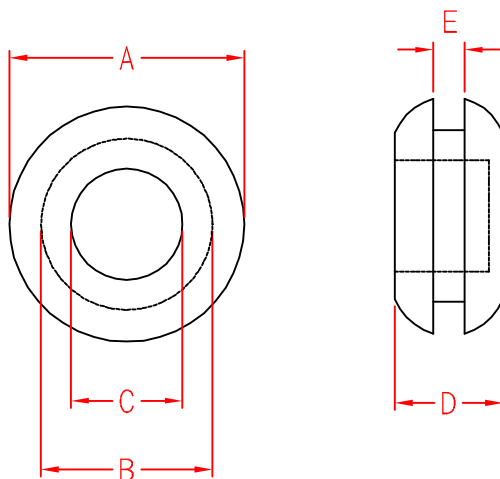

ITEM NO.	A	B	C	D	E
GMC-0603	8.5±0.25	6.0±0.25	3.0±0.25	4.7±0.25	1.7±0.25
GMC-0705	10.2±0.35	7.2±0.25	5.0±0.25	4.4±0.25	1.7±0.25
GMC-1006	13.3±0.35	10.0±0.35	6.4±0.25	6.5±0.25	1.7±0.25
GMC-1108S	15.5±0.35	10.9±0.35	7.8±0.25	7.8±0.25	2.3±0.25
GMC-1410	19.5±0.35	13.9±0.35	10.5±0.35	6.4±0.25	3.4±0.25
GMC-2015	23.7±0.45	20.1±0.45	15.5±0.35	6.1±0.25	1.7±0.25
GMC-2518	29.9±0.45	25.1±0.45	18.9±0.35	7.2±0.25	1.5±0.25
GMC-3225	38.1±0.45	31.7±0.45	25.0±0.45	7.8±0.25	1.5±0.25

承認
 KSS
 104.02.05
 邱平裕

審查

製圖
 KSS
 104.02.05
 謝文通

設計

中文名 護線環		MATERIAL P.V.C.	ITEM NO. GMC TYPE
SCALE		FINISH	NAME GROMMET(closed)

△ ()	TOLERANCE AS FIGURE	△ () 02-05-2015 DATE	REVISIONS K003	R.NO.
-------	------------------------	-----------------------------	-------------------	-------

使用機種

