

## Construction

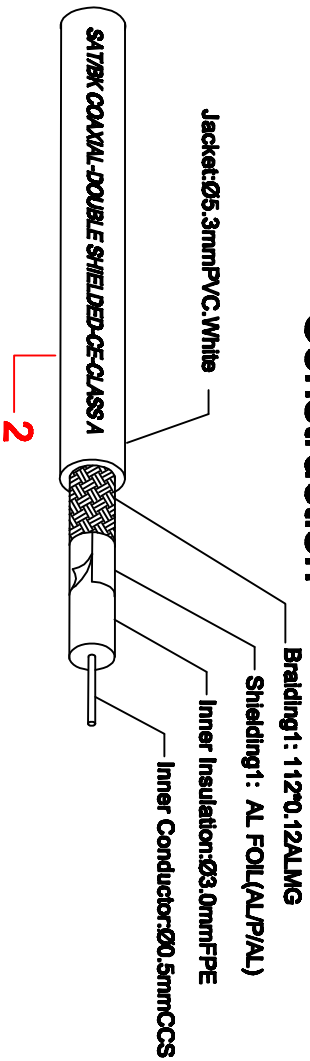

No	Item	Length	Packaging
67341	BQFW 0150	1.5m	1/10/60/160
67342	BQFW 0250	2.5m	1/10/60/120
67343	BQFW 0350	3.5m	1/10/40/80
67344	BQFW 0500	5.0m	1/10/30/60
67345	BQFW 0750	7.5m	1/5/20/40
67346	BQFW 1000	10m	1/5/20/40

## Wiring Method



1. dimensions As shown
2. Insulation resistance ≥ 100 up to 500V =
3. dielectric strength 2 KV 50Hz 2 sec.
4. TESTING: 100% OPEN AND SHORT AND MISWIRE TEST.
5. 100% RoHS COMPLIANT.

4	Copper coil	φ4.5mm H:6mm	2PCS
3	MOLDED1	PVC 4SP White	2*16g
2	CABLE	φ6.3 RGS9 COAXIAL CABLE White(According to the chart)	L
1	CONNECTOR81	F QUICK90° Plug (Nickel plating 100% Shielded)	2set
NO	Item Name	SPEC	QTY
Edition	WEC/000	Scale	
Designed by	ming hong	Item Name	F QUICK 90PLUG TO F QUICK 90PLUG COAXIAL CABLE
Checked by		Item NO	<b>BQFW series cable</b>
Approved by		Unit:	MM
Date	11.28.2013		