

TOP VIEW

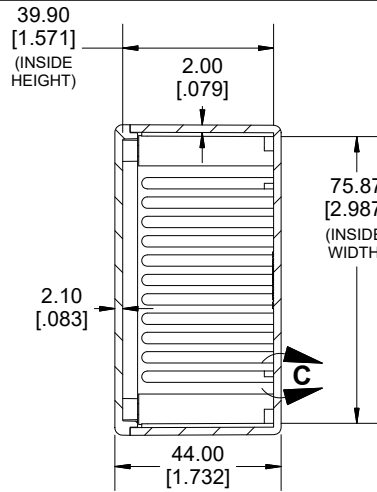

SECTION A-A

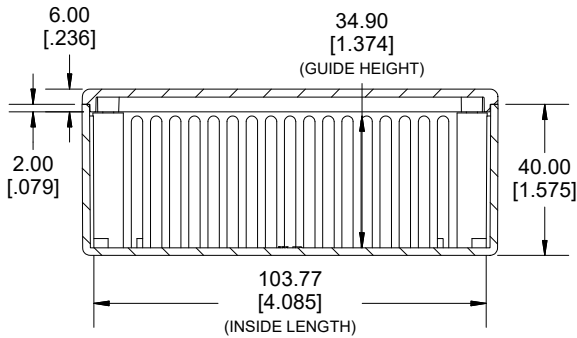
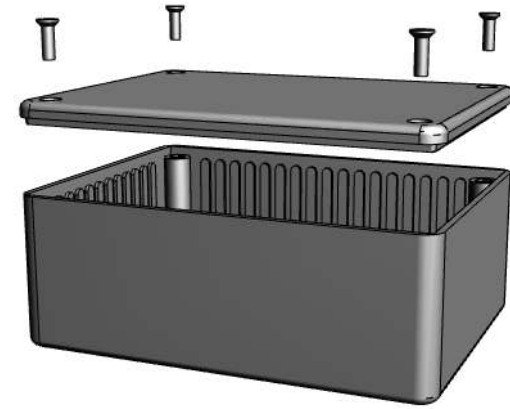

**SECTION B-B
SIDE VIEW**

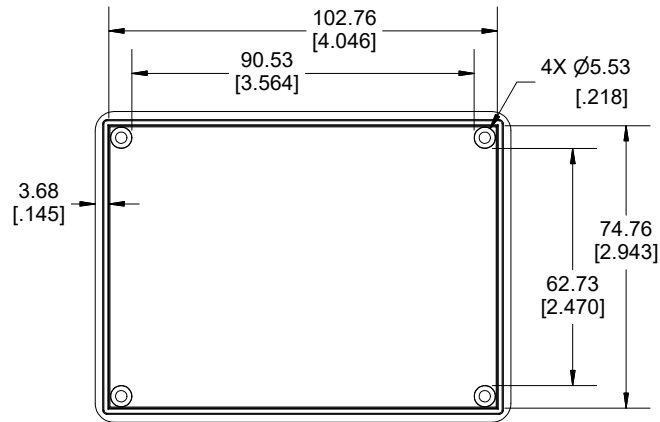
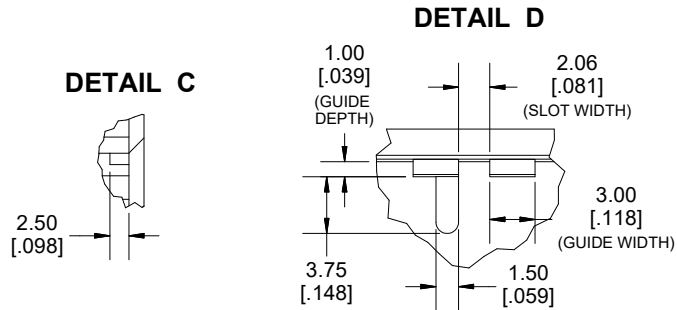

INSIDE LID

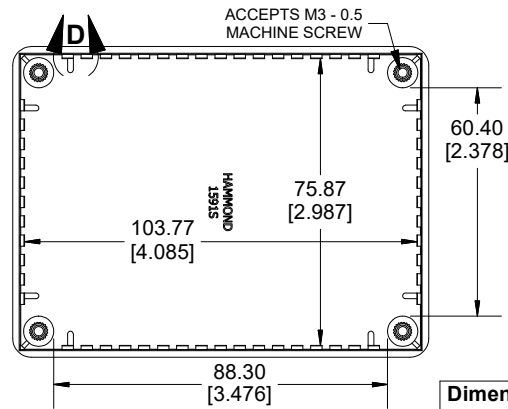

INSIDE BOX

Dimensions:
mm
[inches]

Enclosures can be Factory Modified (Milling, Drilling, Printing etc.)
Contact Factory (modshop@hammfg.com) for quotes
Solid models of this enclosure available in .stp or .x_t
(Part number and text placement/orientation on our products are subject to change,
we do not recommend using them as a locating reference for modification purposes)

NOTE		
Purchased assembly includes box, lid, 4 cover screws, and pre-installed brass inserts. Enclosure made from FRABS or Polycarbonate.		
Recommended Torque: 42-57 ozf.in (30-40 cN.m)		
PART NUMBERS		
1591S Enclosure		
Material	Colour	Part Number
FR ABS UL94 -V0	Beige	1591SBG
	Black	1591SBK
	Blue	1591SBU
	Grey	1591SGY
Translucent Polycarbonate	Ice Blue	1591STBU
	IR Red	1591STRD
	Crystal Clear	1591STCL
Accessories		
Plated Cover screw M3 - 0.5 X 10mm (100Pkg)	1591MS100 (Silver) 1591MS100BK (Black)	
PC Board Card Adapters	1591Z6 (6Pkg)	
	1591Z50 (50 Pkg)	
	1591Z100 (100Pkg)	
Nylon Belt / Pocket clip	1599CLIP (Black)	
	1599CLIPGY (Grey)	
Clear Lids - Flame Retardant Polycarbonate - Lid ONLY	1591SC	

**HAMMOND
MANUFACTURING.**
1591S
www.hammondmfg.com