

Ledtech DUAL DIGIT DISPLAY

0.3" DUAL DIGIT DISPLAY Electrical/Optical Characteristics at $T_A=25^\circ\text{C}$ & $I_F=20\text{mA}$

CHIP COLOR	0.3 inch DUAL DIGIT DUPLEX DRIVE		0.3 inch DUAL DIGIT DIRECT DRIVE		λ_p (nm)	V_F (V)	I_V (mcd)	
	COMMON ANODE	COMMON CATHODE	COMMON ANODE	COMMON CATHODE			TYP.	TYP.
GREEN	LD3022-11	LE3022-11	LA3022-15	LC3022-15	572	2.1	3.9	6.5
YELLOW	LD3032-11	LE3032-11	LA3032-15	LC3032-15	589	2.1	3.1	5.2
ORANGE	LD3042-11	LE3042-11	LA3042-15	LC3042-15	630	2.1	4.5	7.4
ORANGE	LD3042R-11	LE3042R-11	LA3042R-15	LC3042R-15	630	2.1	4.5	7.4
RED	LD3072-11-M1	LE3072-11-M1	LA3072- 15-M1	LC3072- 15-M1	660	1.7	10.4	17.3
RED	LD3052-11	LE3052-11	LA3052- 15	LC3052-15	700	2.1	1.1	1.8

LD30X2-11 COMMON ANODE PIN

NO.	FUNCTION
1. CATHODE	G
2. CATHODE	DP
3. CATHODE	A
4. CATHODE	F
5. COMMON ANODE (DIGIT 2)	
6. CATHODE	D
7. CATHODE	E
8. CATHODE	C
9. CATHODE	B
10. COMMON ANODE (DIGIT 1)	

LE30X2-11 COMMON CATHODE PIN

NO.	FUNCTION
1. ANODE	G
2. ANODE	DP
3. ANODE	A
4. ANODE	F
5. COMMON CATHODE (DIGIT 2)	
6. ANODE	D
7. ANODE	E
8. ANODE	C
9. ANODE	B
10. COMMON CATHODE (DIGIT 1)	

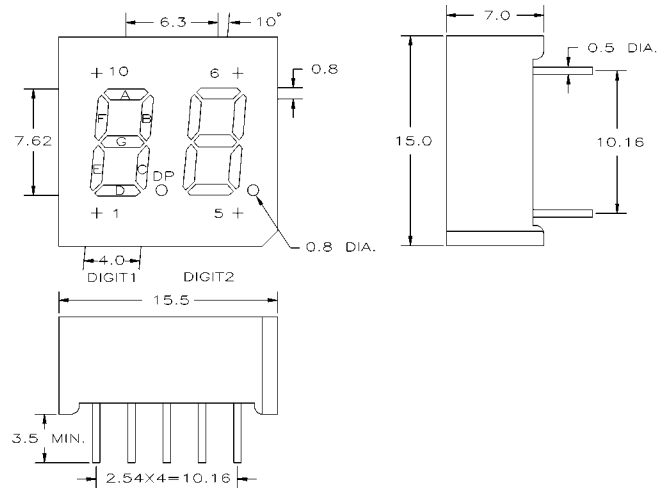

LA30X2-15 COMMON ANODE PIN

NO.	FUNCTION
1. CATHODE	C (DIGIT 1)
2. CATHODE	E (DIGIT 1)
3. CATHODE	D (DIGIT 1)
4. COMMON ANODE (DIGIT 1)	
5. COMMON ANODE (DIGIT 2)	
6. CATHODE	D (DIGIT 2)
7. CATHODE	E (DIGIT 2)
8. CATHODE	C (DIGIT 2)
9. CATHODE	G (DIGIT 2)
10. CATHODE	A (DIGIT 2)
11. CATHODE	F (DIGIT 2)
12. CATHODE	B (DIGIT 2)
13. CATHODE	B (DIGIT 1)
14. CATHODE	F (DIGIT 1)
15. CATHODE	A (DIGIT 1)
16. CATHODE	G (DIGIT 1)

LC30X2-15 COMMON CATHODE PIN

NO.	FUNCTION
1. ANODE	C (DIGIT 1)
2. ANODE	E (DIGIT 1)
3. ANODE	D (DIGIT 1)
4. COMMON CATHODE (DIGIT 1)	
5. COMMON CATHODE (DIGIT 2)	
6. ANODE	D (DIGIT 2)
7. ANODE	E (DIGIT 2)
8. ANODE	C (DIGIT 2)
9. ANODE	G (DIGIT 2)
10. ANODE	A (DIGIT 2)
11. ANODE	F (DIGIT 2)
12. ANODE	B (DIGIT 2)
13. ANODE	B (DIGIT 1)
14. ANODE	F (DIGIT 1)
15. ANODE	A (DIGIT 1)
16. ANODE	G (DIGIT 1)

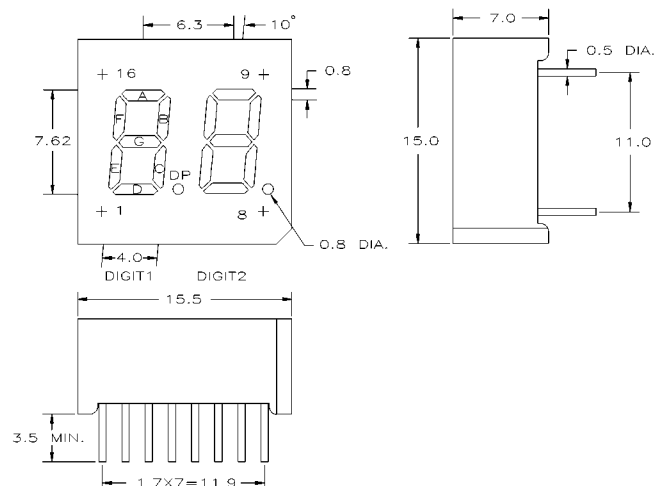

NOTES : 1.ALL DIMENSIONS ARE IN mm, TOLERANCE IS $\pm 0.25\text{mm}$ (0.01") UNLESS OTHERWISE NOTED.
2.THE SLOPE ANGLE OF ANY PIN MAY BE $\pm 5^\circ$ MAX.